



# StormTech®

*Detention • Retention • Recharge*  
Subsurface Stormwater Management™

**Save Valuable Land and  
Protect Water Resources**



## **Isolator™ Row O&M Manual**

StormTech® Chamber System for Stormwater Management

# 1.0 The Isolator™ Row

## 1.1 INTRODUCTION

An important component of any Stormwater Pollution Prevention Plan is inspection and maintenance. The StormTech Isolator Row is a patent pending technique to inexpensively enhance Total Suspended Solids (TSS) removal and provide easy access for inspection and maintenance.



Looking down the Isolator Row from the manhole opening, woven geotextile is shown between the chamber and stone base.

## 1.2 THE ISOLATOR™ ROW

The Isolator Row is a row of StormTech chambers, either SC-310, SC-740 or MC-3500 models, that is surrounded with filter fabric and connected to a closely located manhole for easy access. The fabric-wrapped chambers provide for settling and filtration of sediment as storm water rises in the Isolator Row and ultimately passes through the filter fabric. The open bottom chambers and perforated sidewalls allow storm water to flow both vertically and horizontally out of the chambers. Sediments are captured in the Isolator Row protecting the storage areas of the adjacent stone and chambers from sediment accumulation.

Two different fabrics are used for the Isolator Row. A woven geotextile fabric is placed between the stone and the Isolator Row chambers. The tough geotextile provides a media for storm water filtration and provides a durable surface for maintenance operations. It is also designed to prevent scour of the underlying stone and remain intact during high pressure jetting. A non-woven fabric is placed over the chambers to provide a filter media for flows passing through the perforations in the sidewall of the chamber.

The Isolator Row is typically designed to capture the “first flush” and offers the versatility to be sized on a volume basis or flow rate basis. An upstream manhole not only provides access to the Isolator Row but typically includes a high flow weir such that storm water flowrates or volumes that exceed the capacity of the Isolator Row overtop the over flow weir and discharge through a manifold to the other chambers.

The Isolator Row may also be part of a treatment train. By treating storm water prior to entry into the chamber system, the service life can be extended and pollutants such as hydrocarbons can be captured. Pre-treatment best management practices can be as simple as deep sump catch basins, oil-water separators or can be innovative storm water treatment devices. The design of the treatment train and selection of pretreatment devices by the design engineer is often driven by regulatory requirements. Whether pretreatment is used or not, the Isolator Row is recommended by StormTech as an effective means to minimize maintenance requirements and maintenance costs.

*Note: See the StormTech Design Manual for detailed information on designing inlets for a StormTech system, including the Isolator Row.*

### StormTech Isolator Row with Overflow Spillway (not to scale)

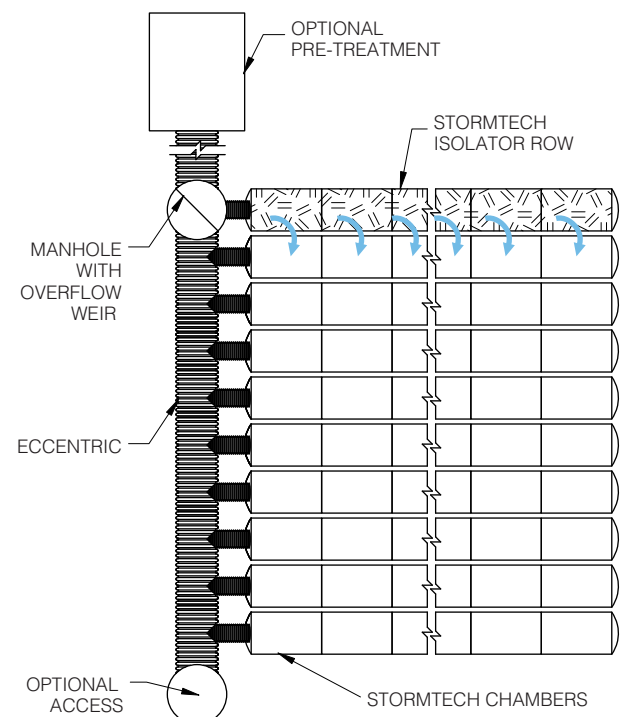

## 2.0 Isolator Row Inspection/Maintenance



### 2.1 INSPECTION

The frequency of Inspection and Maintenance varies by location. A routine inspection schedule needs to be established for each individual location based upon site specific variables. The type of land use (i.e. industrial, commercial residential), anticipated pollutant load, percent imperviousness, climate, etc. all play a critical role in determining the actual frequency of inspection and maintenance practices.

At a minimum, StormTech recommends annual inspections. Initially, the Isolator Row should be inspected every 6 months for the first year of operation. For subsequent years, the inspection should be adjusted based upon previous observation of sediment deposition.

The Isolator Row incorporates a combination of standard manhole(s) and strategically located inspection ports (as needed). The inspection ports allow for easy access to the system from the surface, eliminating the need to perform a confined space entry for inspection purposes.

If upon visual inspection it is found that sediment has accumulated, a stadia rod should be inserted to determine the depth of sediment. When the average depth of sediment exceeds 3 inches throughout the length of the Isolator Row, clean-out should be performed.

### 2.2 MAINTENANCE

The Isolator Row was designed to reduce the cost of periodic maintenance. By “isolating” sediments to just one row, costs are dramatically reduced by eliminating the need to clean out each row of the entire storage bed. If inspection indicates the potential need for maintenance, access is provided via a manhole(s) located on the end(s) of the row for cleanout. If entry into the manhole is required, please follow local and OSHA rules for a confined space entries.



Examples of culvert cleaning nozzles appropriate for Isolator Row maintenance. (These are not StormTech products.)

Maintenance is accomplished with the JetVac process. The JetVac process utilizes a high pressure water nozzle to propel itself down the Isolator Row while scouring and suspending sediments. As the nozzle is retrieved, the captured pollutants are flushed back into the manhole for vacuuming. Most sewer and pipe maintenance companies have vacuum/JetVac combination vehicles. Selection of an appropriate JetVac nozzle will improve maintenance efficiency. Fixed nozzles designed for culverts or large diameter pipe cleaning are preferable. Rear facing jets with an effective spread of at least 45” are best. Most JetVac reels have 400 feet of hose allowing maintenance of an Isolator Row up to 50 chambers long. **The JetVac process shall only be performed on StormTech Isolator Rows that have AASHTO class 1 woven geotextile (as specified by StormTech) over their angular base stone.**

### StormTech Isolator Row (not to scale)

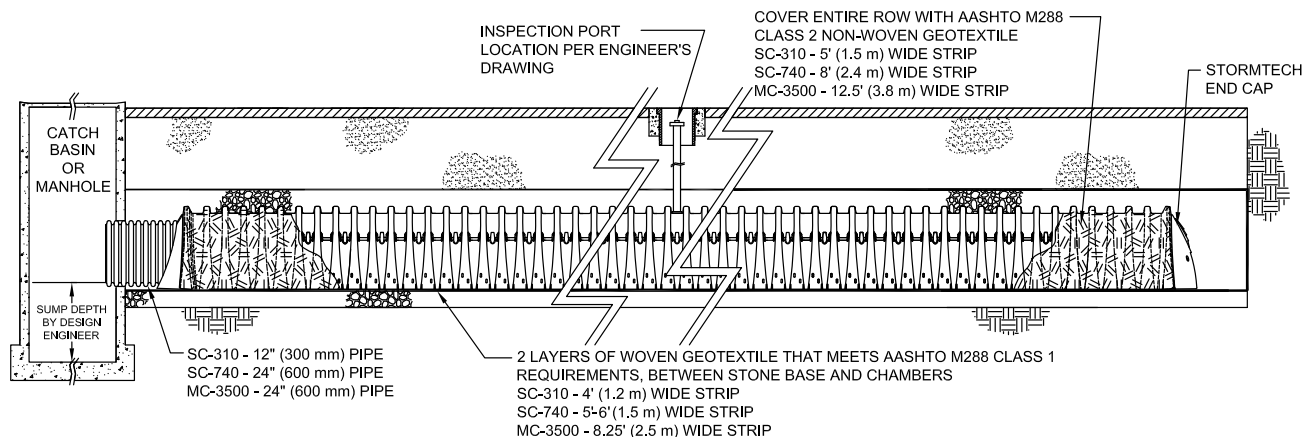

## 3.0 Isolator Row Step By Step Maintenance Procedures

### Step 1) Inspect Isolator Row for sediment

#### A) Inspection ports (if present)

- i. Remove lid from floor box frame
- ii. Remove cap from inspection riser
- iii. Using a flashlight and stadia rod, measure depth of sediment and record results on maintenance log.
- iv. If sediment is at, or above, 3 inch depth proceed to Step 2. If not proceed to step 3.

#### B) All Isolator Rows

- i. Remove cover from manhole at upstream end of Isolator Row
- ii. Using a flashlight, inspect down Isolator Row through outlet pipe
  1. Mirrors on poles or cameras may be used to avoid a confined space entry
  2. Follow OSHA regulations for confined space entry if entering manhole
- iii. If sediment is at or above the lower row of sidewall holes (approximately 3 inches) proceed to Step 2. If not proceed to Step 3.

StormTech Isolator Row (not to scale)

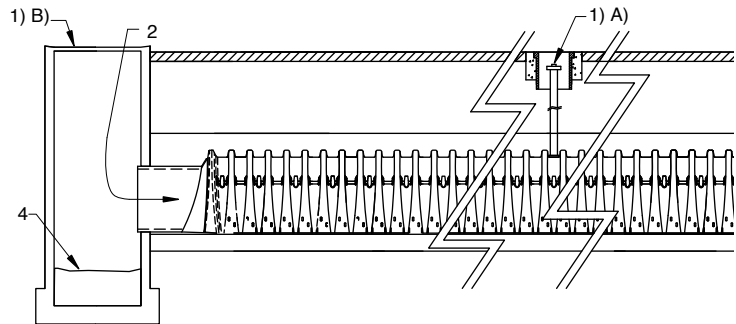

### Step 2) Clean out Isolator Row using the JetVac process

- A) A fixed culvert cleaning nozzle with rear facing nozzle spread of 45 inches or more is preferable
- B) Apply multiple passes of JetVac until backflush water is clean
- C) Vacuum manhole sump as required

### Step 3) Replace all caps, lids and covers, record observations and actions

### Step 4) Inspect & clean catch basins and manholes upstream of the StormTech system

### Sample Maintenance Log

| Date    | Stadia Rod Readings               |                                    | Sediment Depth (1) - (2) | Observations/Actions   | Inspector |
|---------|-----------------------------------|------------------------------------|--------------------------|--|-----------|
|         | Fixed point to chamber bottom (1) | Fixed point to top of sediment (2) |                          |  |           |
| 3/15/01 | 6.3 ft.                           | none                               |                          | New installation. Fixed point is Cl frame at grade                         | djm       |
| 9/24/01 |                                   | 6.2                                | 0.1 ft.                  | Some grit felt   | sm        |
| 6/20/03 |                                   | 5.8                                | 0.5 ft.                  | Mucky feel, debris visible in manhole and in Isolator row, maintenance due | rv        |
| 7/7/03  | 6.3 ft.                           |                                    | 0                        | System jetted and vacuumed   | djm       |



Detention • Retention • Recharge

Subsurface Stormwater Management<sup>SM</sup>

20 Beaver Road, Suite 104 | Wethersfield | Connecticut | 06109  
 860.529.8188 | 888.892.2694 | fax 866.328.8401 | www.stormtech.com

StormTech products are covered by one or more of the following patents: U.S. Patents: 5,401,459; 5,511,903; 5,716,163; 5,588,778; 5,839,844; Canadian Patents: 2,158,418 Other U.S. and Foreign Patents Pending Printed in U.S.A.

© Copyright. All rights reserved. StormTech LLC, 2009

S090809